



Features

- Deep ultraviolet LED
- Mercury free
- Long lifetime
- ESD protection
- Protected by US Patents 9,691,938: 9,871,165: 10,153,395

Applications

- Chemical and biological analysis
- Water quality monitoring
- Gas sensing
- Liquid chromatography

Product overview

The SN3-5T9B5L1 is a powerful deep UV-C emitting device. The TO-39 packaged device delivers 15-degree view angle to enhance the radiant intensity.

The SN3-5T9B5L1 has a peak wavelength of 255 nm for effective water quality detection of COD (chemical oxygen demand) & TOC (total organic carbon), gas detection for ozone and medical analysers. A high optical output power makes the SN3-5T9B5L1 the perfect choice for applications including chemical and biological analysis, water quality monitoring, gas sensing and liquid chromatography.

An ESD protection is integrated in industrial standard TO-39 footprint.

Table 1. Ordering information

Part Number	Wavelength ¹ (nm)	Radiant Flux ² (mW)	Description
SN3-5T9B5L1-TB	Typ. 255	Typ. 0.65	Packing in Tray Box

1. Wavelength measurement is @ 20mA forward current, accuracy is ± 2.0 nm
2. Radiant flux measurement is @20mA forward current, accuracy is $\pm 10\%$

Table 2. LED characteristics

Parameter	Symbol	Min	Typ	Max	Units	Test Conditions
Peak wavelength	λ	250	255	260	nm	1, 3
FWHM	FWHM	-	11	18	nm	1
Viewing angle	degrees	-	19	-		2
Radiant Flux @ 20mA	P_{OUT}	0.35	0.65	-	mW	1, 4
Radiant Intensity @ 20mA	I	3.85	7.15	-	mW/Sr	1, 4
Forward voltage	V	5	-	7	V	1, 5
Thermal resistance junction-case point	R_{TH}	-	10	-	°C/W	1
Power dissipation	P_D	-	0.12	-	W	1

1. $T = 25^{\circ}\text{C}$ ambient, $T_{\text{solder point}} = 25^{\circ}\text{C}$ with Peltier controlled heatsink, forward current = 20mA DC and integrating sphere (radiant flux) or tube (radiant intensity)
2. $T = 25^{\circ}\text{C}$ ambient, $T_{\text{solder point}} = 25^{\circ}\text{C}$ with heatsink, forward current = 20mA DC
3. Wavelength measurement accuracy is ± 2.0 nm
4. Radiant flux/intensity measurement accuracy is $\pm 10\%$
5. Forward voltage accuracy is ± 0.2 V

Table 3. Absolute maximum ratings

Parameter	Symbol	Value	Units	Test Conditions
Storage temperature range	T_{STG}	-40 to +100	°C	
Operating temperature range	T_A	0 to +60	°C	
Forward current	I_F	50	mA	
Junction temperature	T_J	65	°C	
ESD classification		2		JEDEC # JS-001-2010

6. Driving these UVLEDs from a current source is strongly recommended to avoid overdrive damage. The current flowing in a UVLED is an exponential function of the voltage applied and the use of voltage sources to drive a UVLED is likely to exceed the Absolute Maximum Ratings and lead to damage or failure of the UVLED.
7. Stresses beyond those listed in "Absolute Maximum Ratings" may cause permanent damage to the device. The exposure to the absolute maximum rated conditions may affect device reliability.

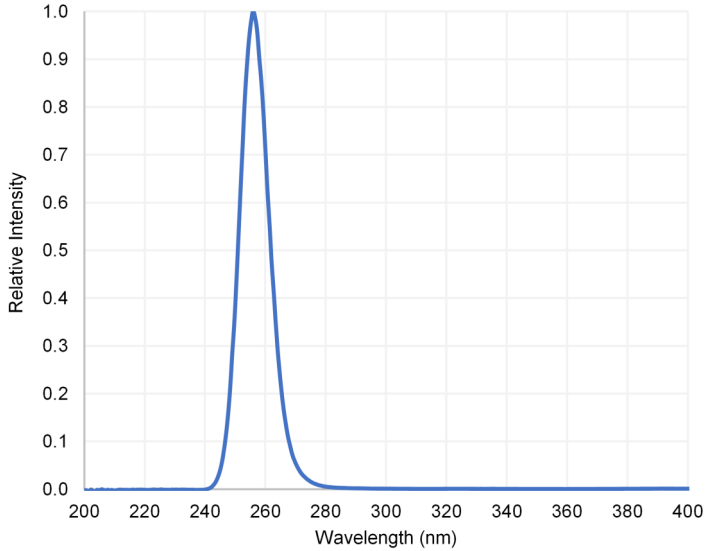

Figure 1. Relative emission intensity vs wavelength
 $T_A=25\text{ }^\circ\text{C}$, $I_F = 20\text{ mA}$

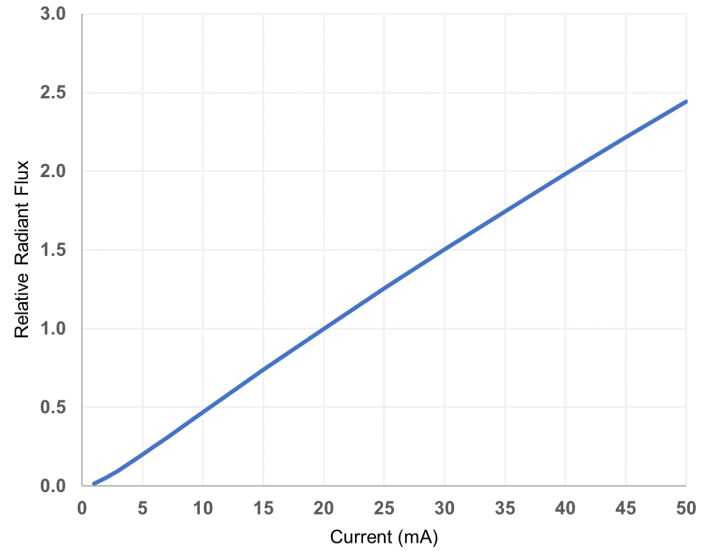

Figure 2. Relative radiant flux vs forward current
 $T_A=25\text{ }^\circ\text{C}$

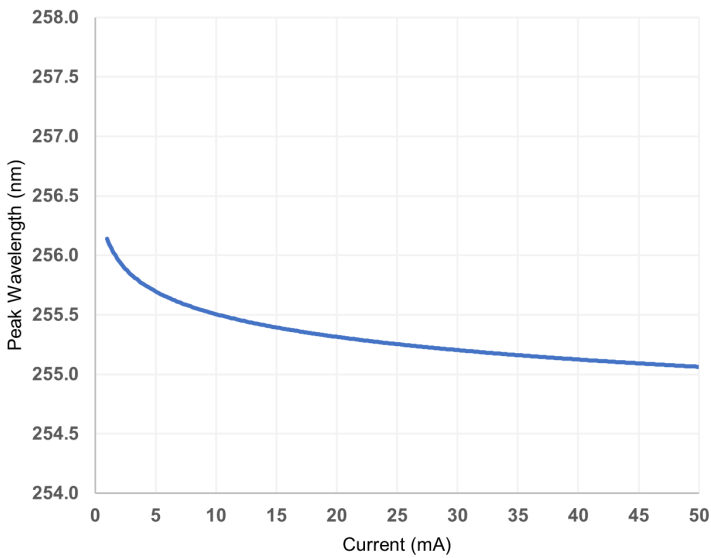

Figure 3. Peak wavelength vs forward current
 $T_A=25\text{ }^\circ\text{C}$

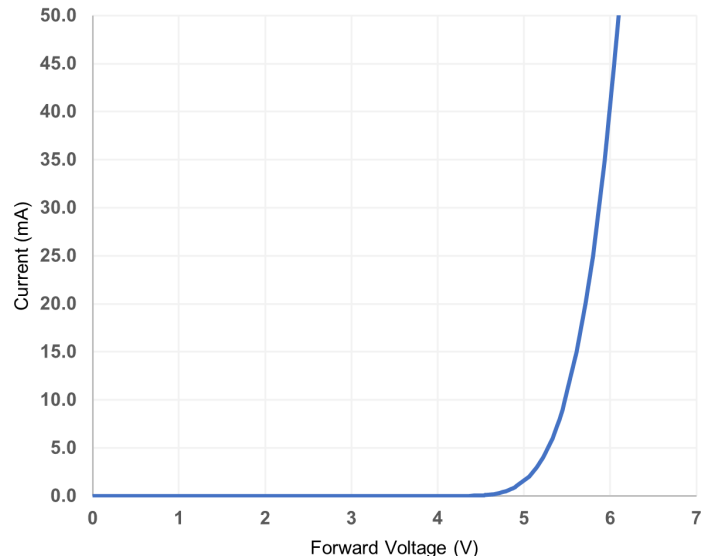

Figure 4. Forward current vs forward voltage
 $T_A=25\text{ }^\circ\text{C}$

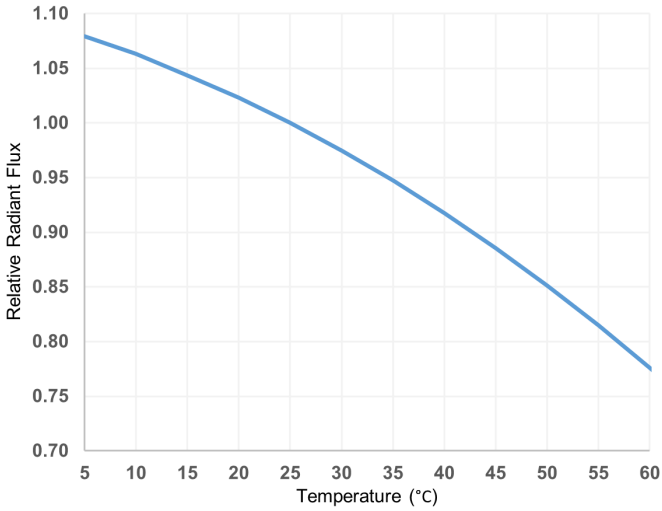

Figure 5. Relative radiant flux vs temperature
 $I_F = 20 \text{ mA}$

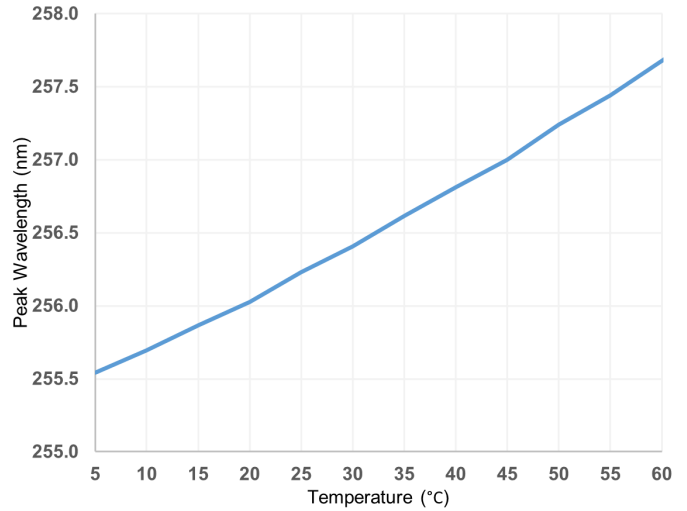

Figure 6. Peak wavelength vs temperature
 $I_F = 20 \text{ mA}$

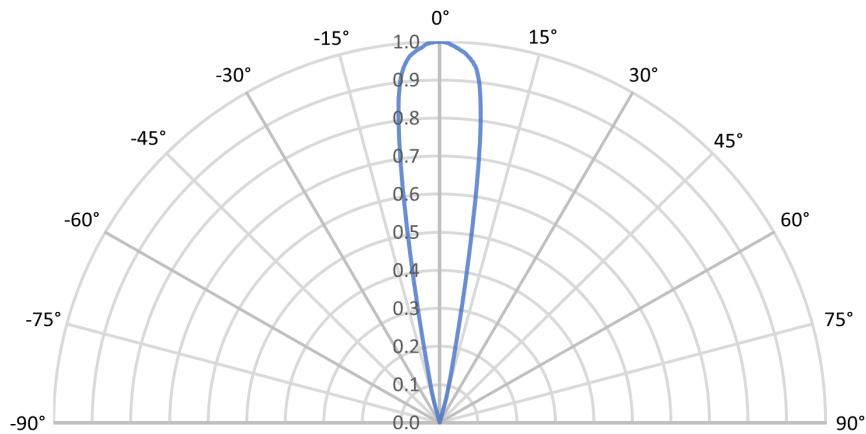

Figure 7. Radiation pattern
 $T_A = 25^\circ\text{C}$, $I_F = 20 \text{ mA}$

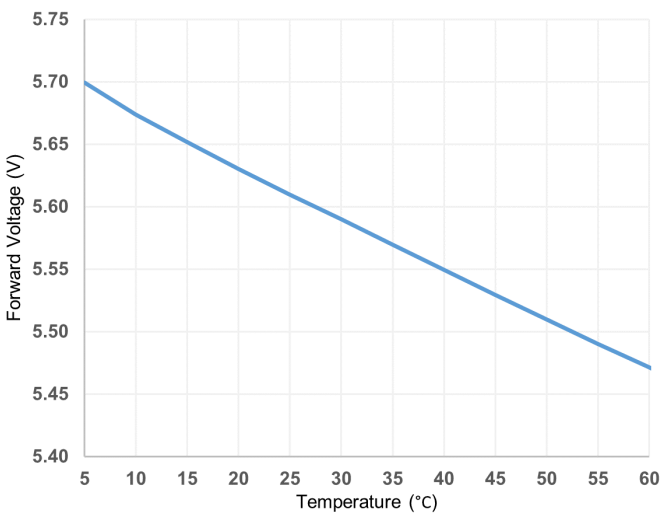

Figure 8. Forward voltage vs temperature
 $I_F = 20 \text{ mA}$

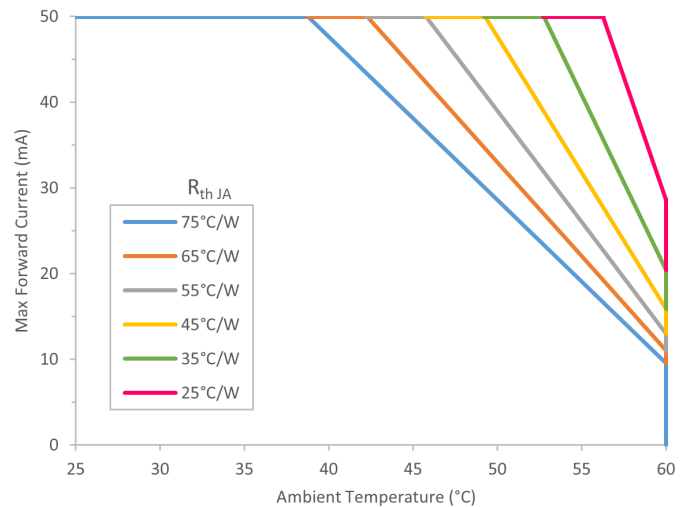

Figure 9. Max Forward current de-rating

Package and layout information

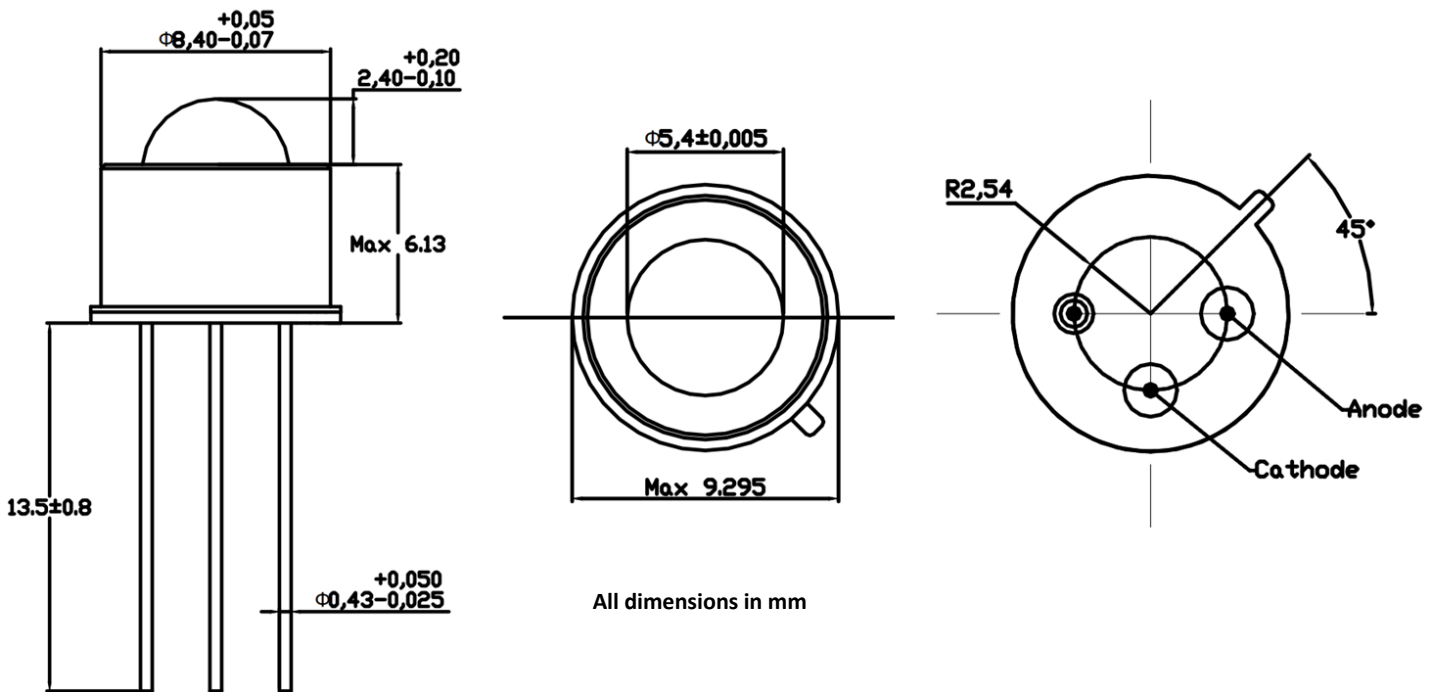

Figure 10. Package dimensions

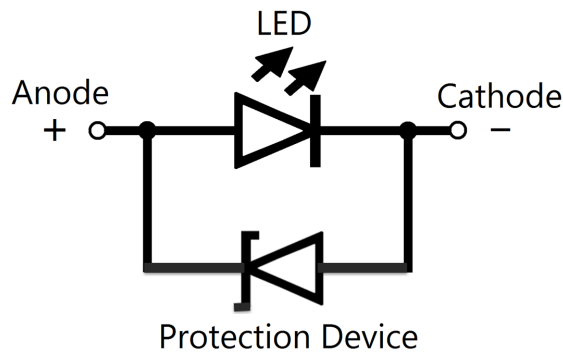

Figure 11. Equivalent circuit

Soldering

Table 4. Soldering conditions

Parameter	Dip Soldering Lead-free solder	Hand Soldering Lead-free solder
Pre-heat	90°C max (backside of PCB)	
Pre-heat time	60 seconds max	
Temperature	260°C max (Solder bath)	300°C max
Soldering time	5 seconds max	3 seconds max

* Distance between melted solder sides to bottom of LED should be 3mm or greater

Soldering Temperature Profile

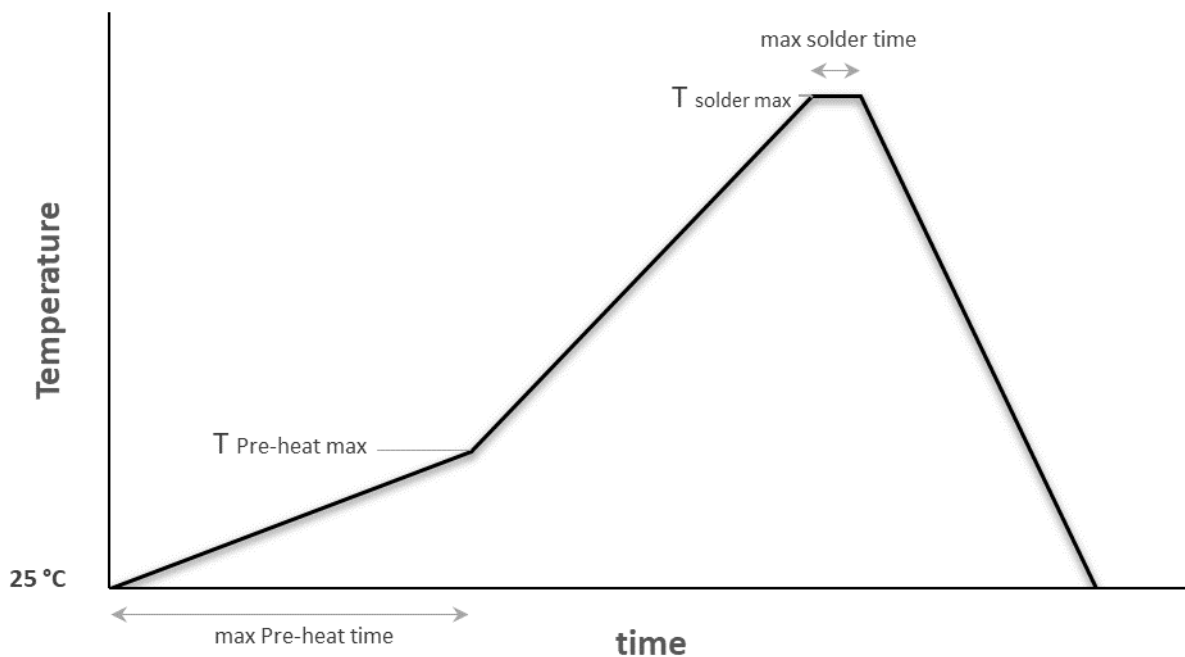

Figure 12. Soldering temperature profile

Recommended usage instructions

Storage

1. Store in a moisture free environment (< 60%RH).
2. Store between 5°C and 30°C.
3. After storing, clean with isopropyl alcohol. Do not use acetone, MKS or ultrasonic baths to clean.

Handling

1. Use ESD tweezers to hold the LED by the sides of the package.
2. Do not touch the optical surface of the LED.
3. Observe appropriate ESD precautions when handling the LED.

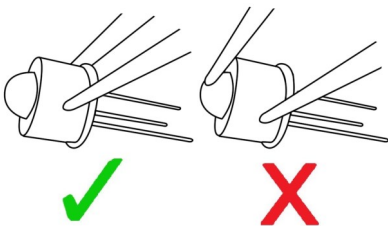

Circuit

1. Driving circuits must be designed to operate the LEDs in forward bias only.
2. A driver IC delivering constant current operation is recommended.
3. The recommended circuit for multiple LEDs involves driving individual load resistances. Each LED can have different forward voltages for the same current.

Safety information

The LED emits invisible UV light during operation. UV light is hazardous to eyes and skin. Long term exposure to UV light increases the risk of skin and eye cancer. Always ensure adequate control measures are in place to prevent exposure to UV light when the LED is operational.

Compliance

RoHS & REACH Compliant.